

This page for 5100 Basic External series is intentionally left blank.

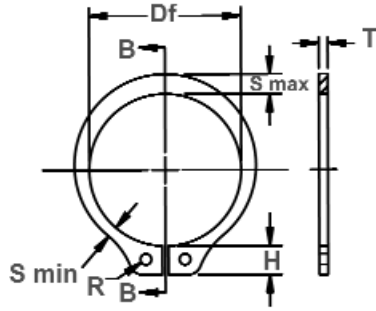

5100 BASIC External



Free Diameter & Ring Measurements with Section B-B

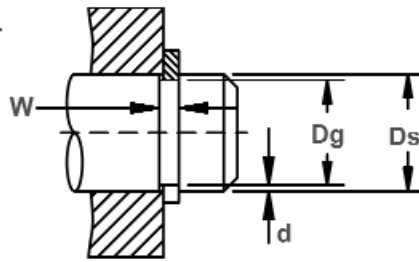

Shaft Diameter & Groove Dimensions

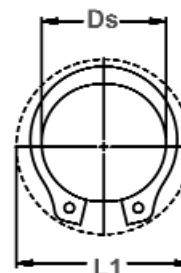

Clearance Diameter Expanded Over Shaft



Clearance Diameter & Gaging Diameter Released in Groove.

RING NO.	SHAFT DIAMETER			GROOVE SIZE			RING SIZE & WEIGHT					CLEARANCE DIA.			i THRUST LD.(lbs.)		
				DIAMETER		WIDTH	DEPTH	FREE DIAMETER		THICKNESS***	Weight Per 1000 pcs.	Expanded over Shaft	Released in Groove	Sqr. Corner	Abutment		
	Ds DEC	Ds FRAC	Ds mm	Dg	Tol.	W	Tol.	d	Df	Tol.						T	Tol.
**5100-12	.125	1/8	3.2	.117		.012		.004	.112		.010	±.001	.018	.222	.214	112	35
**5100-15	.156	5/32	4.0	.146		.012		.005	.142		.010		.037	.27	.260	132	55
**5100-18	.188	3/16	4.8	.175	±.0015	.018	+.002	.006	.168	+.002	.015		.059	.298	.286	244	80
**5100-19	.197	-	5.0	.185	.0015*	.018	-.000	.006	.179	-.004	.015		.063	.319	.307	254	85
**5100-21	.219	7/32	5.6	.205		.018		.007	.196		.015		.074	.338	.324	284	110
**5100-23	.236	15/64	6.0	.222		.018		.007	.215		.015		.086	.355	.341	315	120
5100-25	.250	1/4	6.4	.230		.029		.010	.225		.025		.21	.45	.43	599	175
5100-27	.276	-	7.0	.255		.029		.010	.250		.025		.23	.48	.46	660	195
5100-28	.281	9/32	7.1	.261		.029		.010	.256		.025		.24	.49	.47	670	200
5100-31	.312	5/16	7.9	.290		.029		.011	.281		.025		.27	.54	.52	751	240
5100-34	.344	11/32	8.7	.321	±.002	.029		.011	.309		.025		.31	.57	.55	812	265
5100-35	.354	-	9.0	.330	.002*	.029		.012	.320	+.002	.025		.35	.59	.57	832	300
5100-37	.375	3/8	9.5	.352		.029		.012	.338	-.005	.025		.39	.61	.59	883	320
5100-39	.394	-	10.0	.369		.029		.012	.354		.025		.42	.62	.60	954	335
5100-40	.406	13/32	10.3	.382		.029		.012	.366		.025		.43	.63	.61	964	350
5100-43	.438	7/16	11.1	.412		.029		.013	.395		.025		.50	.66	.64	1035	400
5100-46SP1	.461	-	11.7	.435		.029		.013	.420		.025		.51	.68	.66	1110	460
5100-46	.469	15/32	11.9	.443		.029		.013	.428		.025	±.002	.54	.68	.66	1117	450
5100-50	.500	1/2	12.7	.468	±.002	.039	+.003	.016	.461		.035		.91	.77	.74	1675	550
5100-55	.551	-	14.0	.519	.004*	.039	-.000	.016	.509		.035		.90	.81	.78	1800	600
5100-56	.562	9/16	14.3	.530		.039		.016	.521		.035		1.1	.82	.79	1878	650
5100-59	.594	19/32	15.1	.559		.039		.017	.550		.035		1.2	.86	.83	1979	750
5100-62	.625	5/8	15.9	.588		.039		.018	.579		.035		1.3	.90	.87	2091	800
5100-66	.669	-	17.0	.629		.039		.020	.621	+.005	.035		1.4	.93	.89	2233	950
5100-66	.672	43/64	17.1	.631		.039		.020	.621	-.010	.035		1.4	.93	.89	2233	950
5100-68	.688	11/16	17.5	.646		.046		.021	.635		.042		1.8	1.01	.97	3451	1000
5100-75	.750	3/4	19.0	.704	±.003	.046		.023	.693		.042		2.1	1.09	1.05	3756	1200
5100-78	.781	25/32	19.8	.733	.004*	.046		.024	.722		.042		2.2	1.12	1.08	3959	1300
5100-81	.812	13/16	20.6	.762		.046		.025	.751		.042		2.5	1.15	1.10	4060	1450
5100-84	.844	-	21.4	.791		.046		.026	.780		.042		2.7	1.18	1.13	4200	1500
5100-87	.875	7/8	22.2	.821		.046		.027	.810		.042		2.8	1.21	1.16	4365	1650
5100-93	.938	15/16	23.8	.882		.046		.028	.867		.042		3.1	1.34	1.29	4720	1850
5100-98	.984	63/64	25.0	.926		.046		.029	.910		.042		3.5	1.39	1.34	4923	2000
5100-100	1.000	1	25.4	.940		.046		.030	.925		.042		3.6	1.41	1.35	5024	2100
5100-102	1.023	-	26.0	.961		.046		.031	.946		.042		3.9	1.43	1.37	5126	2250
5100-106	1.062	1-1/16	27.0	.998	±.004	.056	+.004	.032	.982	+.010	.050		4.8	1.50	1.44	6293	2400
5100-112	1.125	1-1/8	28.6	1.059	.005*	.056	-.000	.033	1.041	-.015	.050		5.1	1.55	1.49	6699	2600

**SIZES -12 THRU -23 STANDARD MATERIAL- CARBON STEEL; OPTIONAL MATERIAL- BERYLLIUM COPPER.

* F.I.M. (FULL INDICATOR MOVEMENT)- MAXIMUM ALLOWABLE DEVIATION OF CONCENTRICITY BETWEEN GROOVE & SHAFT.

i BASED ON HOUSINGS/SHAFTS MADE OF COLD ROLLED STEEL. FOR AN EXPLANATION OF FORMULAS USED TO DERIVE THRUST LOAD AND OTHER PERFORMANCE DATA CONTACT THE ROTOR CLIP ENGINEERING DEPARTMENT.

***FOR PLATED RINGS ADD .002" TO THE LISTED MAXIMUM THICKNESS. MAXIMUM THICKNESS WILL BE A MINIMUM OF .0002" LESS THAN THE LISTED GROOVE WIDTH (W) MINIMUM.

5100 BASIC External

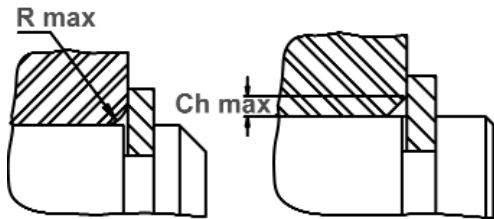

Maximum Corner Radius & Chamfer

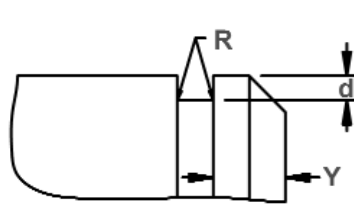

Exploded Groove Profile & Edge Margin (Y)
Maximum bottom radii (R), sharp corners for ring sizes -12 thru -23; .003 for ring sizes -25 thru -35; .005 for sizes -37 thru -100; .010 for ring sizes -102 thru -1000

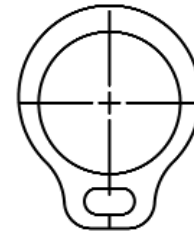

Alternate Lug Design
For Sizes
-12 thru -23

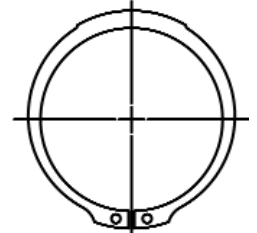

Alternate Design
Manufacturer's Option

RING NO.	LUG HEIGHT		MAXIMUM SECTION		MINIMUM SECTION		HOLE DIAMETER		GAGING DIA.	ALLOWABLE CORNER RADII & CHAMFERS	MAX. LOAD w/ R max or Ch max (lbs.)	EDGE MARGIN	R.P.M. LIMITS Standard Material	
	H	Tol.	S max	Tol.	S min	Tol.	R	Tol.						
**5100-12	.046	±.002	.018	±.0015	.011	±.0015	.026	+.010 -.002	Gd Max	R max	Ch max	P'r	Y	RPM
**5100-15	.054		.026		.016		.026		.148	.010	.006	45	.012	80000
**5100-18	.050		.025		.016		.025		.189	.015	.009	45	.015	80000
**5100-19	.056		.026	.016	.026	.218	.014		.0085	105	.018	80000		
**5100-21	.056		.028	.017	.026	.229	.0145		.009	105	.018	80000		
**5100-23	.056		.030	.019	.026	.252	.015		.009	105	.021	80000		
5100-25	.080	±.003	.035	±.003	.025	±.003	.041	+.010 -.002	.272	.0165	.010	105	.021	80000
5100-27	.081		.035		.024		.041		.290	.018	.011	470	.030	80000
5100-28	.080		.038		.025		.041		.315	.0175	.0105	470	.031	76000
5100-31	.087		.040		.026		.041		.326	.020	.012	470	.033	70000
5100-34	.087		.042		.0265		.041		.357	.020	.012	470	.033	64000
5100-35	.087		.046		.029		.041		.390	.021	.0125	470	.033	62000
5100-37	.088		.050	.0305	.041	.405	.023		.014	470	.036	62000		
5100-39	.087		.052	.031	.041	.433	.026		.0155	470	.036	60000		
5100-40	.087		.054	.033	.041	.452	.027		.016	470	.037	56500		
5100-43	.088		.055	.033	.041	.468	.0285		.017	470	.036	55000		
5100-46SP1	.092		.064	.038	.041	.501	.029		.0175	470	.039	50000		
5100-46	.088		.060	.035	.041	.540	.015		.017	470	.039	42000		
5100-50	.108	.065	.040	.047	.540	.031	.018	470	.039	42000				
5100-55	.108	.053	.036	.047	.574	.034	.020	910	.048	40000				
5100-56	.108	.072	.041	.047	.611	.027	.0165	910	.048	36000				
5100-59	.109	.076	.043	.047	.644	.038	.023	910	.048	35000				
5100-62	.110	.080	.045	.047	.680	.0395	.0235	910	.052	32000				
5100-66	.110	.082	.043	.047	.715	.0415	.025	910	.055	30000				
5100-66	.110	.082	.043	.047	.756	.040	.024	910	.060	29000				
5100-68	.136	.084	.048	.052	.758	.040	.024	910	.060	29000				
5100-75	.136	.092	.051	.052	.779	.042	.025	1340	.063	28000				
5100-78	.136	.094	.052	.052	.850	.046	.0275	1340	.069	26500				
5100-81	.136	.096	.054	.052	.883	.047	.028	1340	.072	25500				
5100-84	.137	.100	.057	.052	.914	.047	.028	1340	.075	24500				
5100-87	.137	.104	.057	.052	.950	.047	.028	1340	.078	24000				
5100-93	.166	.110	.063	.078	.987	.051	.0305	1340	.081	23000				
5100-98	.167	.114	.064	.078	1.054	.055	.033	1340	.084	21500				
5100-100	.167	.116	.065	.078	1.106	.056	.0335	1340	.087	20500				
5100-102	.168	.118	.066	.078	1.122	.057	.034	1340	.090	20000				
5100-106	.181	.122	.069	.078	1.147	.058	.035	1340	.093	19500				
5100-112	.182	.128	.071	.078	1.192	.060	.036	1950	.096	19000				
											1950	.099	18800	

FOR HARDNESS SPECIFICATIONS, SEE END OF THIS SECTION.



5100 BASIC External

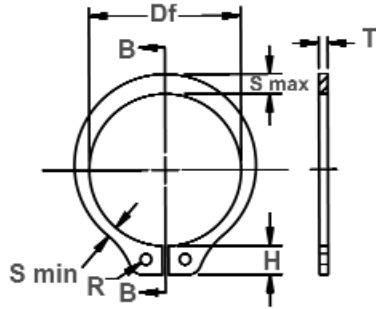

Free Diameter & Ring Measurements with Section B-B

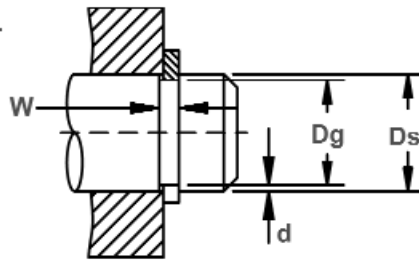

Shaft Diameter & Groove Dimensions

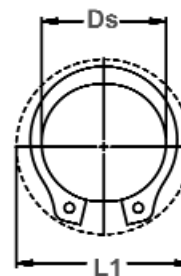

Clearance Diameter Expanded Over Shaft



Clearance Diameter & Gaging Diameter Released in Groove.

RING NO.	SHAFT DIAMETER			GROOVE SIZE			RING SIZE & WEIGHT				CLEARANCE DIA.			THRUST LD.(lbs.) Sqr. Corner Abutment			
				DIAMETER		WIDTH	DEPTH	FREE DIAMETER		THICKNESS***		Weight Per 1000 pcs.	Expanded over Shaft	Released in Groove	Pr	Pg	
	Ds DEC	Ds FRAC	Ds mm	Dg	Tol.	W	Tol.	d	Df	Tol.	T						Tol.
5100-118	1.188	1-3/16	30.2	1.118		.056		.035	1.098		.050		5.6	1.61	1.54	7105	2950
5100-125	1.250	1-1/4	31.7	1.176		.056		.037	1.156		.050		5.9	1.69	1.62	7460	3250
5100-131	1.312	1-5/16	33.3	1.232	±.004	.056		.040	1.214	+ .010	.050	±.002	6.8	1.75	1.67	7866	3700
5100-137	1.375	1-3/8	34.9	1.291	.005*	.056		.042	1.272	- .015	.050		7.2	1.80	1.72	8222	4100
5100-143	1.438	1-7/16	36.5	1.350		.056		.044	1.333		.050		8.1	1.87	1.79	8628	4500
5100-150	1.500	1-1/2	38.1	1.406		.056		.047	1.387		.050		9.0	1.99	1.90	8932	5000
5100-156	1.562	1-9/16	39.7	1.468		.068		.047	1.446		.062		12.4	2.10	2.01	11571	5200
5100-162	1.625	1-5/8	41.3	1.529		.068	+ .004	.048	1.503		.062		13.2	2.17	2.08	12028	5500
5100-168	1.688	1-11/16	42.9	1.589		.068	- .000	.049	1.560		.062		14.8	2.24	2.15	12535	5850
5100-175	1.750	1-3/4	44.4	1.650	±.005	.068		.050	1.618	+ .013	.062		15.3	2.31	2.21	12992	6200
5100-177	1.772	-	45.0	1.669	.005*	.068		.051	1.637	- .020	.062		15.4	2.33	2.23	13144	6400
5100-181	1.812	1-13/16	46.0	1.708		.068		.052	1.675		.062		15.6	2.38	2.28	13449	6650
5100-187	1.875	1-7/8	47.6	1.769		.068		.053	1.735		.062		17.3	2.44	2.34	13906	7000
5100-196	1.969	1-31/32	50.0	1.857		.068		.056	1.819		.062		18.0	2.57	2.46	14565	7800
5100-200	2.000	2	50.8	1.886		.068		.057	1.850		.062		19.0	2.60	2.49	14819	8050
5100-206	2.062	2-1/16	52.4	1.946		.086		.058	1.906		.078		25.0	2.68	2.57	19234	8450
5100-212	2.125	2-1/8	54.0	2.003		.086		.061	1.964		.078		26.1	2.78	2.66	19793	9150
5100-215	2.156	2-5/32	54.8	2.032		.086		.062	1.993		.078		26.3	2.81	2.69	20097	9450
5100-225	2.250	2-1/4	57.1	2.120		.086		.065	2.081	+ .015	.078	±.003	27.7	2.88	2.76	21011	10350
5100-231	2.312	2-5/16	58.7	2.178		.086		.067	2.139	- .025	.078		28.0	2.94	2.81	21518	10950
5100-237	2.375	2-3/8	60.3	2.239		.086		.068	2.197		.078		29.2	3.06	2.93	22127	11400
5100-243	2.438	2-7/16	61.9	2.299		.086		.069	2.255		.078		29.5	3.07	2.94	22736	11900
5100-250	2.500	2-1/2	63.5	2.360		.086		.070	2.313		.078		29.7	3.17	3.03	23345	12350
5100-255	2.559	-	65.0	2.419		.086		.070	2.377		.078		33.9	3.18	3.04	23853	12650
5100-262	2.625	2-5/8	66.7	2.481	±.006	.086	+ .005	.072	2.428		.078		35.0	3.30	3.16	24462	13350
5100-268	2.688	2-11/16	68.3	2.541	.006*	.086	- .000	.073	2.485		.078		36.0	3.37	3.23	25071	13850
5100-275	2.750	2-3/4	69.8	2.602		.103		.074	2.543		.093		42.5	3.48	3.34	30551	14400
5100-287	2.875	2-7/8	73.0	2.721		.103		.077	2.659		.093		48.5	3.60	3.45	31973	15650
5100-293	2.938	2-15/16	74.6	2.779		.103		.079	2.717	+ .020	.093		50.0	3.66	3.51	32683	16400
5100-300	3.000	3	76.2	2.838		.103		.081	2.775	- .030	.093		52.0	3.60	3.44	33394	17200
5100-306	3.062	3-1/16	77.8	2.898		.103		.082	2.832		.093		47.5	3.74	3.58	34003	17750
5100-312	3.125	3-1/8	79.4	2.957		.103		.084	2.892		.093		58.0	3.85	3.69	34815	18550
5100-315	3.156	3-5/32	80.2	2.986		.103		.085	2.920		.093		59.0	3.88	3.71	35119	18950
5100-325	3.250	3-1/4	82.5	3.076		.103		.087	3.006		.093		62.0	3.93	3.76	36134	20000
5100-334	3.346	3-11/32	85.0	3.166		.103		.090	3.092		.093		64.0	4.02	3.85	37251	21000
5100-343	3.438	3-7/16	87.3	3.257		.103		.090	3.179		.093		66.0	4.14	3.96	38266	21900
5100-350	3.500	3-1/2	88.9	3.316		.120		.092	3.237		.109		72.0	4.16	3.98	45574	22800

* F.I.M. (FULL INDICATOR MOVEMENT)- MAXIMUM ALLOWABLE DEVIATION OF CONCENTRICITY BETWEEN GROOVE & SHAFT.

† BASED ON HOUSINGS/SHAFTS MADE OF COLD ROLLED STEEL. FOR AN EXPLANATION OF FORMULAS USED TO DERIVE THRUST LOAD AND OTHER PERFORMANCE DATA CONTACT THE ROTOR CLIP ENGINEERING DEPARTMENT.

***FOR PLATED RINGS ADD .002" TO THE LISTED MAXIMUM THICKNESS. MAXIMUM THICKNESS WILL BE A MINIMUM OF .0002" LESS THAN THE LISTED GROOVE WIDTH (W) MINIMUM.

5100 BASIC External

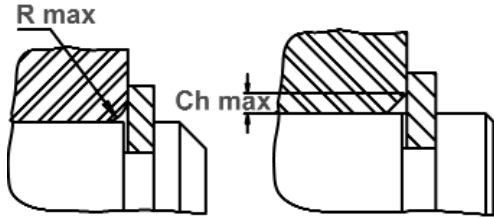

Maximum Corner Radius & Chamfer

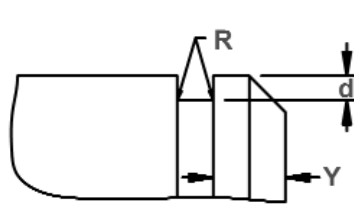

Exploded Groove Profile & Edge Margin (Y)
Maximum bottom radii (R), sharp corners for ring sizes -12 thru -23; .003 for ring sizes -25 thru -35; .005 for sizes -37 thru -100; .010 for ring sizes -102 thru -1000

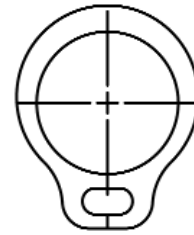

Alternate Lug Design
For Sizes
-12 thru -23

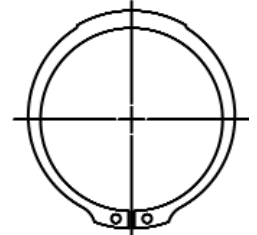

Alternate Design
Manufacturer's Option

RING NO.	LUG HEIGHT		MAXIMUM SECTION		MINIMUM SECTION		HOLE DIAMETER		GAGING DIA. Gd Max.	ALLOWABLE CORNER RADII & CHAMFERS		MAX. LOAD w/ R max or Ch max (lbs.)	EDGE MARGIN		R.P.M. LIMITS Standard Material
	H	Tol.	S max	Tol.	S min	Tol.	R	Tol.		R max	Ch max		P'r	Y	
5100-118	.182	±.004	.132	±.006	.072	±.006	.078	+.015 -.002	1.325	.064	.0385	1950	.105	18000	
5100-125	.183		.140		.076		.078		1.396	.068	.041	1950	.111	17000	
5100-131	.183		.146		.076		.078		1.458	.068	.041	1950	.120	16500	
5100-137	.184		.152		.082		.078		1.529	.072	.043	1950	.126	16000	
5100-143	.184		.160		.086		.078		1.600	.076	.045	1950	.132	15000	
5100-150	.214		.168		.091		.120		1.668	.079	.047	1950	.141	14800	
5100-156	.235		.172		.093		.125		1.740	.082	.049	3000	.141	14000	
5100-162	.235		.180		.097		.125		1.812	.087	.052	3000	.144	13200	
5100-168	.235		.184		.099		.125		1.877	.090	.054	3000	.148	13000	
5100-175	.237		.188		.101		.125		1.945	.091	.054	3000	.150	12200	
5100-177	.237		.190		.102		.125		1.967	.092	.055	3000	.154	11700	
5100-181	.262		.192		.102		.125		2.010	.092	.055	3000	.156	11500	
5100-187	.239		.196		.104		.125		2.076	.094	.056	3000	.159	11000	
5100-196	.262		.200		.106		.125		2.170	.094	.056	3000	.168	10500	
5100-200	.262		.204		.108		.125		2.205	.096	.057	3000	.171	10000	
5100-206	.267		.208		.111		.125		2.275	.098	.059	5000	.174	9600	
5100-212	.280		.212		.113		.125		2.337	.098	.059	5000	.183	9500	
5100-215	.280		.212		.113		.125		2.366	.097	.058	5000	.186	9400	
5100-225	.280		.220		.116		.125		2.466	.100	.060	5000	.195	9200	
5100-231	.267		.222		.118		.125		2.528	.100	.060	5000	.201	9000	
5100-237	.292	.224	.119	.125	2.591	.100	.060	5000	.204	8800					
5100-243	.268	.228	.120	.125	2.657	.102	.061	5000	.207	8600					
5100-250	.292	.232	.122	.125	2.724	.104	.062	5000	.210	8400					
5100-255	.268	.238	.125	.125	2.792	.108	.065	5000	.210	8200					
5100-262	.292	.242	.127	.125	2.860	.1095	.066	5000	.216	8000					
5100-268	.292	.246	.129	.125	2.926	.1115	.067	5000	.219	7900					
5100-275	.324	.248	.131	.125	2.992	.112	.067	7350	.222	7600					
5100-287	.324	.256	.133	.125	3.122	.115	.069	7350	.231	7300					
5100-293	.324	.260	.136	.125	3.187	.116	.070	7350	.237	7200					
5100-300	.264	.264	.138	.125	3.252	.117	.070	7350	.243	6700					
5100-306	.300	.300	.131	.125	3.294	.107	.064	7350	.246	6600					
5100-312	.324	.272	.141	.125	3.383	.120	.072	7350	.252	6600					
5100-315	.324	.274	.143	.125	3.415	.1205	.072	7350	.255	6500					
5100-325	.300	.300	.145	.125	3.515	.123	.074	7350	.261	6400					
5100-334	.300	.300	.147	.125	3.613	.126	.076	7350	.270	6000					
5100-343	.308	.292	.148	.125	3.712	.129	.077	7350	.270	5900					
5100-350	.285	.285	.148	.125	3.764	.122	.073	10500	.276	5900					

FOR HARDNESS SPECIFICATIONS, SEE END OF THIS SECTION.



5100 BASIC External

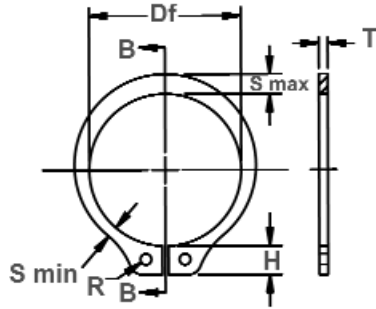

Free Diameter & Ring Measurements with Section B-B

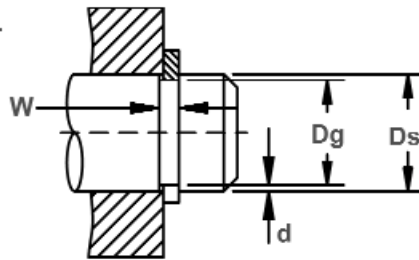

Shaft Diameter & Groove Dimensions

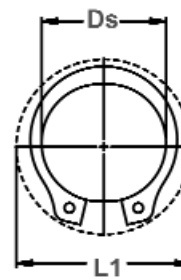

Clearance Diameter Expanded Over Shaft



Clearance Diameter & Gaging Diameter Released in Groove.

RING NO.	SHAFT DIAMETER			GROOVE SIZE			RING SIZE & WEIGHT				CLEARANCE DIA.			i THRUST LD.(lbs.) Sqr. Corner Abutment			
				DIAMETER		WIDTH	DEPTH	FREE DIAMETER		THICKNESS***	Weight Per 1000 pcs.	Expanded over Shaft	Released in Groove	Ring Safety Factor of 4	Groove Safety Factor of 2		
	Ds DEC	Ds FRAC	Ds mm	Dg	Tol.	W	Tol.	d	Df	Tol.						T	Tol.
5100-354	3.543	-	90.0	3.357		.120		.093	3.277		.109		73.0	4.25	4.07	46183	23300
5100-362	3.625	3-5/8	92.1	3.435		.120		.095	3.352		.109		76.0	4.33	4.14	47299	24300
5100-368	3.688	3-11/16	93.7	3.493		.120		.097	3.410		.109		80.0	4.31	4.12	48010	25300
5100-375	3.750	3-3/4	95.2	3.552	±.006	.120	+ .005	.099	3.468	+ .020	.109	±.003	83.0	4.52	4.33	48822	26200
5100-387	3.875	3-7/8	98.40	3.673	.006*	.120	- .000	.101	3.584	- .030	.109		88.0	4.62	4.42	50446	27700
5100-393	3.938	3-15/16	100.0	3.734		.120		.102	3.642		.109		95.0	4.70	4.50	51359	28400
5100-400	4.000	4	101.6	3.792		.120		.104	3.700		.109		101.0	4.76	4.56	52171	29400
5100-412	4.125	4-1/8	104.8	3.915		.120		.105	3.800		.109		101.2	5.00	4.78	53200	29800
5100-425	4.250	4-1/4	108.0	4.065		.120		.092	3.989		.109		112.0	4.98	4.80	55419	27600
5100-437	4.375	4-3/8	111.1	4.190		.120		.092	4.106		.109		115.0	5.22	5.04	57043	28400
5100-450	4.500	4-1/2	114.3	4.310		.120		.095	4.223		.109		132.0	5.37	5.18	58667	30200
5100-475	4.750	4-3/4	120.6	4.550		.120		.100	4.458		.109		113.0	5.62	5.42	61915	33600
5100-500	5.000	5	127.0	4.790		.120		.105	4.692		.109		149.0	5.77	5.56	65163	37100
5100-525	5.250	5-1/4	133.3	5.030		.139		.110	4.927		.125		190.0	6.10	5.89	78460	40800
5100-550	5.500	5-1/2	139.7	5.265	±.007	.139	+ .006	.117	5.162	+ .020	.125	±.004	202.5	6.45	6.22	82215	45500
5100-575	5.750	5-3/4	146.0	5.505	.006*	.139	- .000	.122	5.396	- .040	.125		220.0	6.69	6.45	85971	49600
5100-600	6.000	6	152.4	5.745		.139		.127	5.631		.125		210.0	6.91	6.66	89625	53800
5100-625	6.250	6-1/4	158.7	5.985		.174		.132	5.866		.156		282.0	7.26	7.00	116522	58300
5100-650	6.500	6-1/2	165.1	6.225		.174		.137	6.100	+ .020	.156		330.0	7.62	7.35	121191	62900
5100-675	6.750	6-3/4	171.4	6.465		.174		.142	6.335	- .050	.156		356.0	7.83	7.55	125860	67700
5100-700	7.000	7	177.8	6.705		.174		.147	6.570		.156		371.0	7.86	7.78	130529	72700
5100-725	7.250	7-1/4	184.2	6.942		.209		.154	6.775		.187		510.0	7.59	8.13	162096	78900
5100-750	7.500	7-1/2	190.5	7.180		.209		.160	7.009		.187		534.0	8.73	8.41	167678	84800
5100-775	7.750	7-3/4	196.9	7.420	±.008	.209	+ .008	.165	7.243	+ .050	.187	±.005	545.0	8.85	8.52	173261	90450
5100-800	8.000	8	203.2	7.660	.006*	.209	- .000	.170	7.478	- .130	.187		640.0	9.25	8.91	178843	96100
5100-825	8.250	8-1/4	209.6	7.900		.209		.175	7.712		.187		665.0	9.54	9.19	184426	102100
5100-850	8.500	8-1/2	215.9	8.140		.209		.180	7.947		.187		692.0	9.79	9.43	190008	108100
5100-875	8.750	8-3/4	222.3	8.380		.209		.185	8.181		.187		712.0	10.40	10.00	195591	114450
5100-900	9.000	9	228.6	8.620		.209		.190	8.415		.187		737.0	10.60	10.22	201173	120800
5100-925	9.250	9-1/4	234.9	8.860		.209		.195	8.650		.187		760.0	10.85	10.50	206756	128225
5100-950	9.500	9-1/2	241.3	9.100		.209		.200	8.885		.187		785.0	11.10	10.70	212338	134200
5100-975	9.750	9-3/4	247.6	9.338		.209		.206	9.120		.187		845.0	11.35	10.95	217921	142000
5100-1000	10.000	10	254.0	9.575		.209		.212	9.355		.187		910.0	11.60	11.20	223503	149800

* F.I.M. (FULL INDICATOR MOVEMENT)- MAXIMUM ALLOWABLE DEVIATION OF CONCENTRICITY BETWEEN GROOVE & SHAFT.
 † BASED ON HOUSINGS/SHAFTS MADE OF COLD ROLLED STEEL. FOR AN EXPLANATION OF FORMULAS USED TO DERIVE THRUST LOAD AND OTHER PERFORMANCE DATA CONTACT THE ROTOR CLIP ENGINEERING DEPARTMENT.
 ***FOR PLATED RINGS ADD .002" TO THE LISTED MAXIMUM THICKNESS. MAXIMUM THICKNESS WILL BE A MINIMUM OF .0002" LESS THAN THE LISTED GROOVE WIDTH (W) MINIMUM.

HARDNESS RANGES: STAINLESS STEEL RINGS (PH 15-7MO)			
RING TYPE	SIZE RANGE	SCALE	ROCKWELL HARDNESS
5100-	25-81	30N	63-69.5
	87+	C	44-51

5100 BASIC External

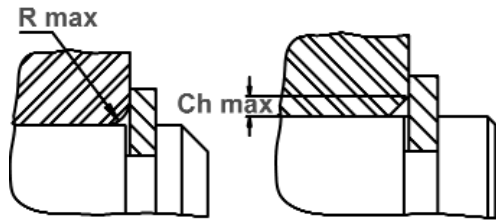

Maximum Corner Radius & Chamfer

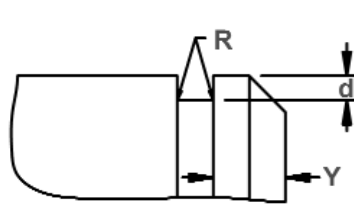

Exploded Groove Profile & Edge Margin (Y)
Maximum bottom radii (R), sharp corners for ring sizes -12 thru -23; .003 for ring sizes -25 thru -35; .005 for sizes -37 thru -100; .010 for ring sizes -102 thru -1000

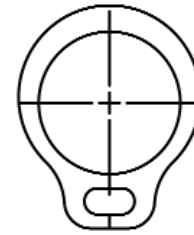

Alternate Lug Design
For Sizes
-12 thru -23

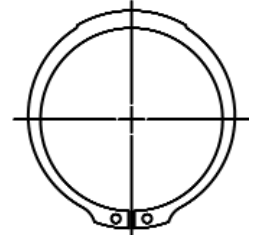

Alternate Design
Manufacturer's Option

RING NO.	LUG HEIGHT		MAXIMUM SECTION		MINIMUM SECTION		HOLE DIAMETER		GAGING DIA.	ALLOWABLE CORNER RADII & CHAMFERS		MAX. LOAD w/ R max or Ch max (lbs.)	EDGE MARGIN	R.P.M. LIMITS Standard Material
	H	Tol.	S max	Tol.	S min	Tol.	R	Tol.		Gd Max.	R max			
	5100-354	.310	±.005	.310	±.008	.149	±.008	.125	+.015 -.002	3.809	.123	.074	10500	.279
5100-362	.310	.310		.153		.125		3.898		.127	.076	10500	.285	5700
5100-368	.310	.310		.156		.125		3.966		.130	.078	10500	.291	5600
5100-375	.342	.342		.160		.125		4.037		.133	.080	10500	.297	5500
5100-387	.342	.342		.163		.125		4.169		.137	.082	10500	.303	5100
5100-393	.342	.342		.163		.125		4.230		.137	.082	10500	.306	5200
5100-400	.342	.342		.163		.125		4.288		.135	.081	10500	.312	5000
5100-412	.380	.318		.165		.125		4.410		.135	.081	10500	.315	4900
5100-425	.342	.342		.176		.125		4.558		.146	.088	10500	.276	4800
5100-437	.342	.342		.176		.125		4.683		.146	.088	10500	.276	4700
5100-450	.405	.405	.185	.125	4.860	.102	.061	10500	.285	4500				
5100-475	.429	.303	.136	.125	4.996	.115	.069	10500	.300	4200				
5100-500	.405	±.008	.405	±.010	.194	±.010	.156	+.020 -.005	5.346	.165	.099	10500	.315	4000
5100-525	.435		.435		.211		.156		5.605	.169	.101	13500	.330	3900
5100-550	.435		.435		.209		.156		5.867	.175	.105	13500	.351	3700
5100-575	.435		.435		.220		.156		6.134	.184	.110	13500	.366	3500
5100-600	.435		.435		.171		.156		6.302	.143	.086	13500	.381	3400
5100-625	.485		.485		.176		.156		6.568	.148	.089	21000	.396	3100
5100-650	.485		.485		.236		.156		6.905	.191	.114	21000	.411	3000
5100-675	.515		.515		.246		.187		7.172	.200	.120	21000	.426	3000
5100-700	.515		.515		.256		.187		7.439	.208	.125	21000	.441	2900
5100-725	.545		.545		.267		.187		7.700	.214	.128	30000	.460	2800
5100-750	.545	.545	.277	.187	7.963	.220	.132	30000	.480	2700				
5100-775	.560	±.012	.560	±.015	.285	±.015	.187		8.228	.227	.136	30000	.495	2600
5100-800	.560		.560		.294		.187		8.493	.235	.141	30000	.510	2500
5100-825	.580		.580		.304		.187		8.758	.242	.146	30000	.525	2400
5100-850	.580		.580		.314		.187		9.023	.250	.150	30000	.540	2300
5100-875	.735		.591		.322		.187		9.280	.258	.155	30000	.555	2200
5100-900	.735		.609		.333		.187		9.557	.267	.160	30000	.570	2200
5100-925	.735		.625		.341		.187		9.830	.274	.164	30000	.585	2100
5100-950	.735		.642		.350		.187		10.086	.281	.168	30000	.600	2100
5100-975	.735		.658		.358		.187		10.340	.287	.172	30000	.618	2000
5100-1000	.735		.675		.367		.187		10.610	.294	.176	30000	.636	2000

LARGER SIZES MAY BE AVAILABLE UPON REQUEST.

HARDNESS RANGES: CARBON STEEL RINGS (SAE 1060-1090)

RING TYPE	SIZE RANGE	SCALE	ROCKWELL HARDNESS
5100-	25-46	30N	69.5-73
	50-81	30N	66-71
	84-102	C	47-53
	106-343	C	47-52
	350-700	C	44-51
	725-1000	C	40-47

HARDNESS RANGES: BERYLLIUM COPPER RINGS

RING TYPE	SIZE RANGE	SCALE	ROCKWELL HARDNESS
5100-	12-23	15N	77-82*
	25-102	30N	56.5-62
	106+	C	37-43

*HARDNESS CAN NOT BE CHECKED WITH ANY DEGREE OF ACCURACY DIRECTLY ON THESE RINGS.